

Front Access

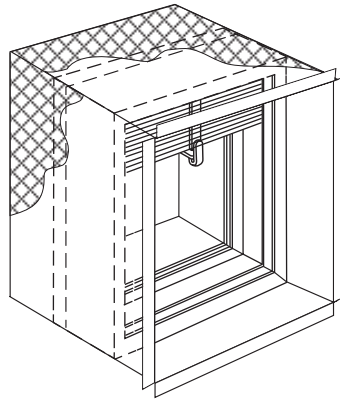

Out-of-Wall



SEE COMPLETE MARKING
ON PRODUCT

UL/ULC File: R27700

The following installation instructions are UL approved to be used with the following CVS Models:
SSD-3V-OW-211, -212, SSD-AF-OW-211, -212,
FSD-3V-OW-211, -212, FSD-AF-OW-211, -212,
FD-OW, FDD-OW, FD-SL-OW, FDD-SL-OW,
FD-MB-3V-OW, FD-MB-AF-OW, FDD-MB-3V-OW,
FDD-MB-AF-OW.

Application & General Notes:

These installation instructions apply to Out-of-Wall (-OW) Fire Dampers and Out-of-Wall (-OW) and Front Access(-FA) Smoke and Combination Fire/Smoke Dampers that are mounted outside the plane of a UL* approved fire partition. These dampers are designed for operation in the vertical or horizontal orientation with blades running horizontal.

Safety Warning:

Read all installation, operating and maintenance instructions thoroughly before installing or servicing this equipment. Improper installation, adjustment, alteration, service or maintenance can cause property damage, injury or death.

Receiving & Handling:

Check for damage when this product is received. If damage is found, record all necessary information on the bill of lading and file a claim with the final carrier. Check to be sure that all parts of the shipment are accounted for.

*When UL is referred to in this document, it represents UL/ULC (Underwriter's Laboratories of United States and Canada).

This IOM manual is the property of the owners, and is required for future maintenance. Please leave it with the owner when the job is complete.

Installation Supplements:

- Installing Fire, Smoke and Combination Fire/Smoke Dampers in a Shaft Wall
- Framing Requirements for Wood or Steel Stud Walls
- UL Approved Breakaway Duct Connections
- Optional Sealing of Dampers in Fire and Smoke Rated Walls or Floors
- Installing the Smoke Detector

Other Installation References:

- Fire Damper IOM
- Smoke Damper IOM
- Combination Fire/Smoke IOM

Other Installation References:

Electrical input may be needed for products discussed within this IOM. All wiring shall be done in accordance with the latest edition of the National Electrical Code ANSI/NFPA-70, any local codes that may apply and wiring diagrams developed in compliance with the job or project design and specifications.

Electrical input work should be performed by a qualified electrician. Verify power before wiring actuator. CVS is not responsible for damage to or failure of the unit caused by incorrect field wiring.

Follow all instructions carefully.

TABLE OF CONTENTS

Pre-Installation Guidelines 2
 Max. Size Table for CVS Fire, Smoke & Fire/Smoke Dampers 2
 Damper Sleeves 3
 Grille Mount Install Method3-4
 Continuous Duct Install Method4-5
 Type B & C Out-Of-Wall Applications 6
 Actuator Connections 7
 Fire Damper Operation, Testing & Maintenance 7

Pre-Installation Notes & Guidelines:

These notes and guidelines are formulated in order to aid in completing the damper installation in a timely and efficient manner.

- A. Inspect damper for damage before installing
- B. Dampers must be installed free from twisting or racking
- C. DO NOT compress or stretch the damper into the opening
- D. DO NOT lift the damper by the blades or actuator (handle damper using frame or sleeve)
- E. The damper must be protected from dirt, dust and foreign materials before and after installation
- F. When painting, wall-texturing, insulating or any other foreign material is being sprayed within 5 feet of the damper, the damper must be sufficiently covered and protected
- G. Suitable access inside the duct and to the damper must be created for inspection and service of the damper per NFPA 90A and local authority having jurisdiction

Table 1: Maximum Size Out-of-Wall Fire, Smoke & Fire/Smoke Dampers:

MODEL	VERTICAL				HORIZONTAL			
	SINGLE SECTION		MULTI-SECTION		SINGLE SECTION		MULTI-SECTION	
	1.5 HOUR	3 HOUR	1.5 HOUR	3 HOUR	1.5 HOUR	3 HOUR	1.5 HOUR	3 HOUR
FD-MB-3V-OW, -FA	36x48 (914x1219)	36x48 (914x1219)	108x96 (2743x2438)	72x48 (1828x1219)	36x48 (914x1219)	36x48 (914x1219)	72x48 (1828x1219)	72x48 (1828x1219)
FD-MB-AF-OW, -FA	36x48 (914x1219)	36x48 (914x1219)	108x96 (2743x2438)	72x48 (1828x1219)	36x48 (914x1219)	36x48 (914x1219)	N/A	N/A
FDD-MB-3V-OW	36x48 (914x1219)	N/A	42x48 (1067x1219)	N/A	36x48 (914x1219)	N/A	42x48 (1067x1219)	N/A
FDD-MB-3V-FA	36x48 (914x1219)	N/A	N/A	N/A	N/A	N/A	N/A	N/A
FDD-MB-AF-OW	36x48 (914x1219)	N/A	42x48 (1067x1219)	N/A	36x48 (914x1219)	N/A	42x48 (1067x1219)	N/A
FDD-MB-AF-FA	36x48 (914x1219)	N/A	N/A	N/A	N/A	N/A	N/A	N/A
FSD/SSD-OW ²	36x48 (914x1219)	N/A	42x48 (1067x1219)	N/A	36x48 (914x1219)	N/A	42x48 (1067x1219)	N/A
FSD/SSD-FA ²	36x48 (914x1219)	N/A	N/A	N/A	36x48 (914x1219)	N/A	N/A	N/A

(All dimensions in parentheses () are in millimeters).

¹Includes all sub-models: -MB-3V, -MB-AF, etc.

²Includes all sub-models: -3V, -AF, Class 1, Class 2, etc.

OUT-OF-WALL DAMPER SLEEVES

Damper Sleeves:

All fire, smoke (optional) and fire/smoke dampers must be installed in a sleeve *at the factory*. Due to the nature of the installation, field fabricated sleeves are not an option. The damper must be ordered with a sleeve and wrapped in insulation as per CVS's UL listing.

Guidelines:

- A.** Sleeves must be of the SAME GAUGE or heavier than the duct to which it is attached if one of the UL approved break-away connections is used (see UL Approved Breakaway Duct Connections IIS).
- B.** Gauges shall conform to SMACNA or ASHRAE duct standards.
- C.** Sleeves shall not extend beyond the fire barrier more than 6" (152mm) unless an actuator or factory installed access door is supplied, then the sleeve may extend up to 16" (406mm).
- D.** When mounted in the sleeve, the beginning of the damper frame cannot be more than 6" away from the wall or floor (see Figure 1:A-B).
- E.** The sleeve shall terminate at both sides of the wall or floor while remaining within the above parameters.
- F.** If a rigid connection is used then the sleeve shall be a minimum of 16 gauge (1.6mm) for dampers up to 36" (914mm) wide by 24" (610mm) high and 14 gauge (2mm) for dampers exceeding either of those dimensions.

Figure 1: Grille Mount Installation

Fig. 1-A

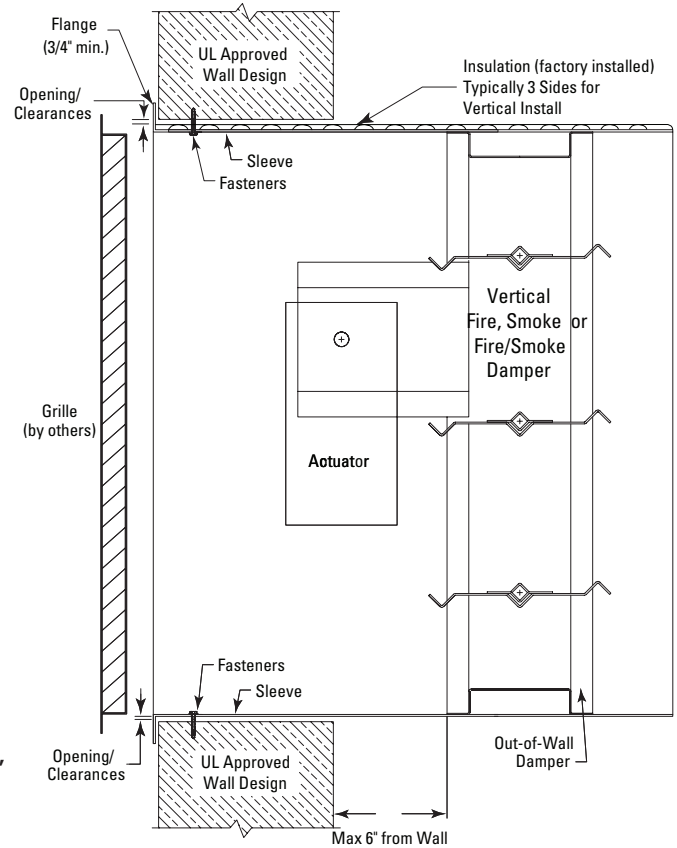

GRILLE MOUNT INSTALL METHOD

Opening/Clearances:

The fire barrier opening shall be larger than the damper in order to allow for thermal expansion and ease of installation (see Figure 1- A). The opening shall be a minimum of 1/4" (6mm) and a maximum of 1/2" (13mm).

Important Note: The clearances mentioned above are for the total clearance for the damper and does not necessarily need to be met on every side of the damper.

Fig. 1-B

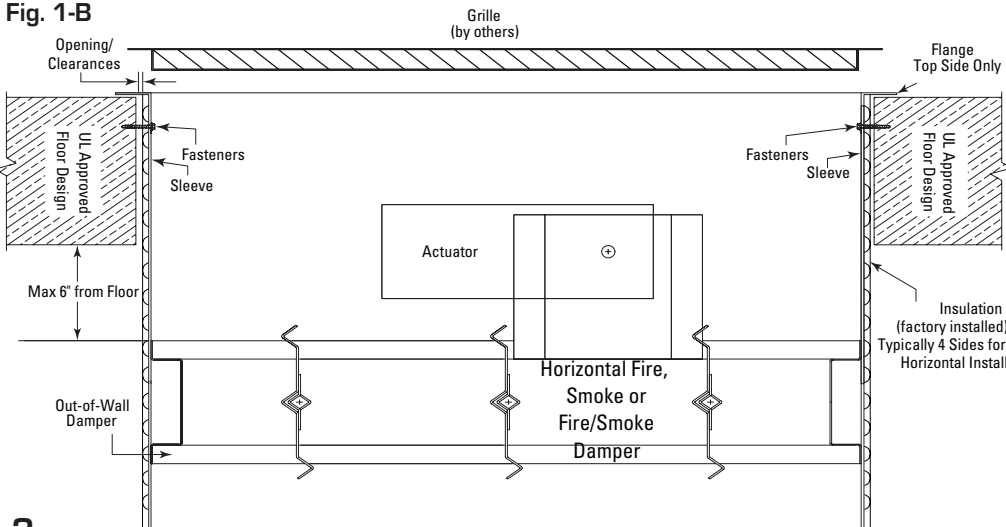

No materials (i.e. Fire Stop, Mineral Wool, etc.) are to be placed in this clearance between the damper sleeve and the wall/floor opening.

GRILLE MOUNT INSTALL METHOD

Guidelines:

The Grille Mount Install Method (Figure 1:A-D) is approved for the following:

- A.** Masonry/concrete walls or floors and stud/gypsum walls.
- B.** 1 ½ Hour rated dampers.
- C.** Vertical (see Figure 1-A on previous page) or horizontal (see Figure 1-B on previous page) (flange on top side only) orientation.
- D.** The maximum size shall be 36" (914mm) wide by 48" (1219mm) high up to the maximum multi-section UL approved damper size (see Underwriter's Laboratories Listings for maximum assembly sizes) and refer to Table 1 on page 2 of this IOM for individual model maximum sizes.

Installation:

- A.** This method uses a minimum of 3/4" (19mm) high by 20 gauge steel flange on one end of the sleeve (see Figure 1: C-D).
- B.** The damper is then placed in the opening so that the flange rests flush up to the partition (see Figures 1: A-B on previous page).
- C.** If an angle is added, it shall be a minimum of 1"x1" (25mmx25mm) by 18 gauge steel and fastened with any of the following approved fasteners:
 - 1. #10 sheet metal screws 3. 1/2" (13mm) welds
 - 2. ¼" (6mm) nut and bolts 4. 3/16" (5mm) steel rivets
- D.** The sleeve is to be fastened to the partition (see Figure 1: C-E) on 6" (152mm) centers with no more than 2" (51mm) from each end and a minimum of 2 fasteners per side/leg using #10 (M5) self-tapping concrete anchors or concrete screws engaging the fire partition a minimum of 1-1/2" (38mm) for masonry/concrete partitions or #10 (M5) screws long enough to penetrate the J-Runners and E-Stud by a minimum of 3/8" (10mm) for stud/gypsum partitions (see Figure 1-D).
- E.** In a steel stud application, the sleeve flange may be placed in front of or behind the drywall attaching directly to the metal studs (see Figure 1-C).

CONTINUOUS DUCT INSTALL METHOD

Opening/Clearances:

The fire barrier opening shall be larger than the damper in order to allow for thermal expansion and ease of installation. The opening shall be a minimum of 1/4" (6mm) and a maximum of 1/2" (13mm).

Important Note: The clearances mentioned above are for the total clearance for the damper and does not necessarily need to be met on every side of the damper.

No materials (i.e. Fire Stop, Mineral Wool, etc.) are to be placed in this clearance between the damper sleeve and the wall/floor opening.

Fig. 1-C
Grille Mount "Out"
Steel/Gypsum

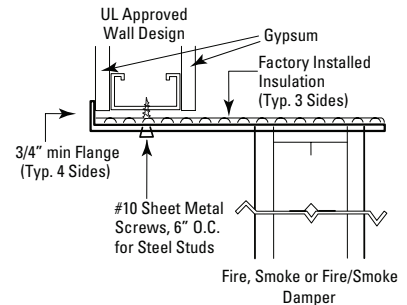

Fig. 1-D
Grille Mount "In"
Steel/Gypsum

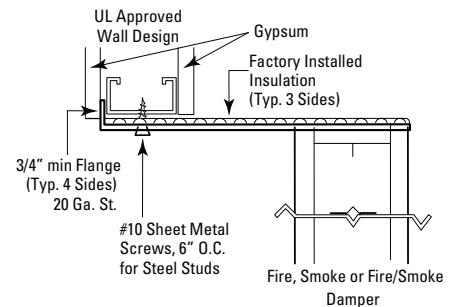

Fig. 1-E

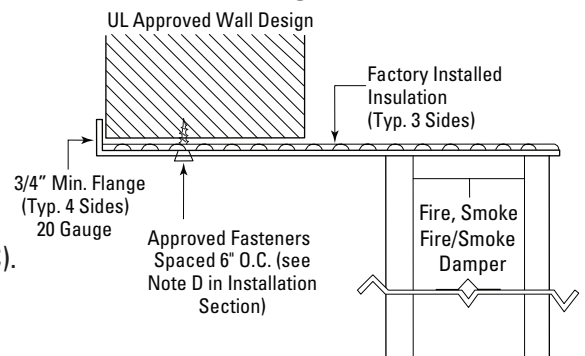
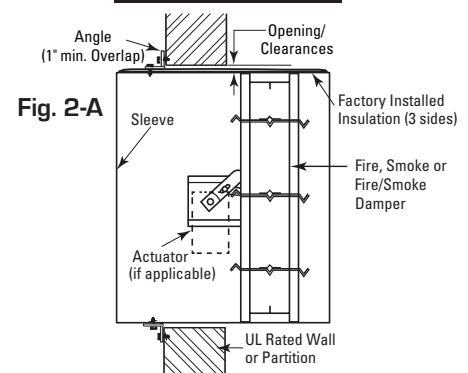

Figure 2: Continuous Duct Installation



CONTINUOUS DUCT INSTALL METHOD (cont.)

Figure 2: Continuous Duct Installation

Guidelines:

The Continuous Duct Method (Figure 2: A-E) is approved for the following:

- A. Masonry/concrete walls or floors and stud/gypsum walls.
- B. 1 ½ Hour rated dampers
- C. Vertical (see Figure 2-A on previous page) or horizontal (see Figure 2-B) (angle on top side only) orientation
- D. The maximum size shall be 36" (914mm) wide by 48" (1219mm) high up to the maximum multi-section UL approved damper size (see Underwriter's Laboratories Listings for maximum assembly sizes) and refer to CVS's maximum size chart in this document for individual model max sizes

Installation:

- A. This method uses one set of angles to secure the damper in the opening (see Figure 2: A-B).
- B. The angle shall be either CVS's Framed Retaining Angles (model FRA) OR minimum of 1-1/2"x1-1/2" (38 mm x 38mm) by 16 gauge and fastened to the sleeve of the damper on 6" (152mm) centers, not more than 2" (51mm) from each end with a minimum of 2 fasteners per side/leg using any of the following approved fasteners (see Fig. 2-C):
 - 1. #10 sheet metal screws
 - 2. ¼" (6mm) nut and bolts
 - 3. 1/2" (13mm) welds
 - 4. 3/16" (5mm) steel rivets
- C. The angles are to overlap the partition a minimum of 1" (25mm) (see Figure 2: C-D).
- D. The angles are also to be fastened to the partition on 6" (152mm) centers with no more than 2" (51mm) from each end with a minimum of 2 fasteners per side/leg using #10 (M5) self-tapping concrete anchors or concrete screws engaging the fire partition a minimum of 1-1/2" (38mm) for masonry/concrete partitions or #10 (M5) screws long enough to penetrate the J-Runners and E-Stud by a minimum of 3/8" (10mm) for stud/gypsum partitions (see Figure 2:C-D).
- E. When the duct work terminates at the damper or installation prohibits the angles from turning out/away from the partition, angles may be reversed and turned inward as in Figure 2-E (leg turned into the opening) while maintaining proper expansion clearances (refer to above section "Opening/Clearances").
- F. In steel stud applications, the angle can be placed in front of or behind the drywall attaching directly to the studs (see Figure 2: C-D).

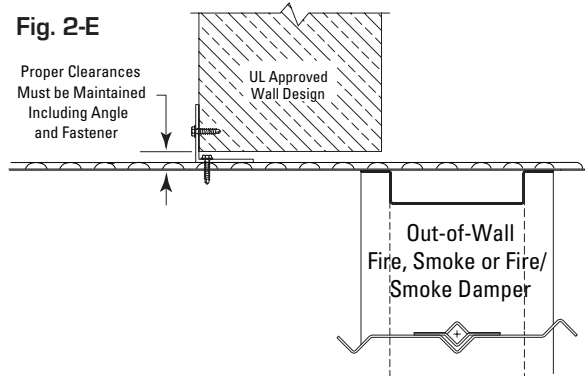
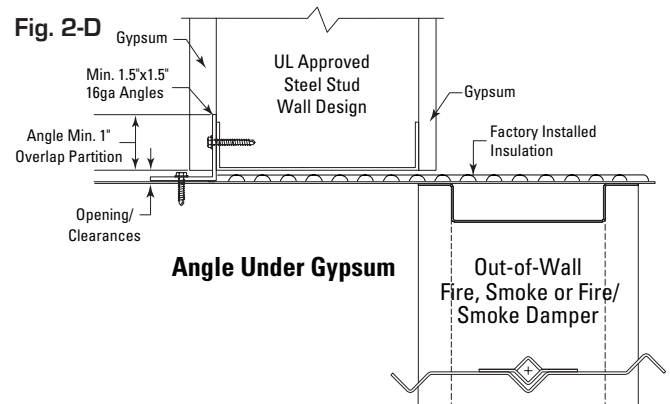
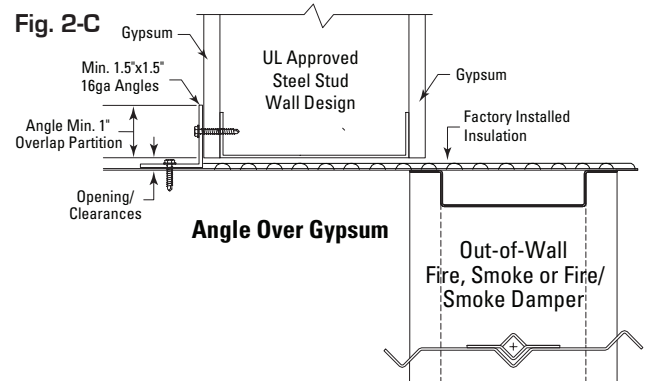
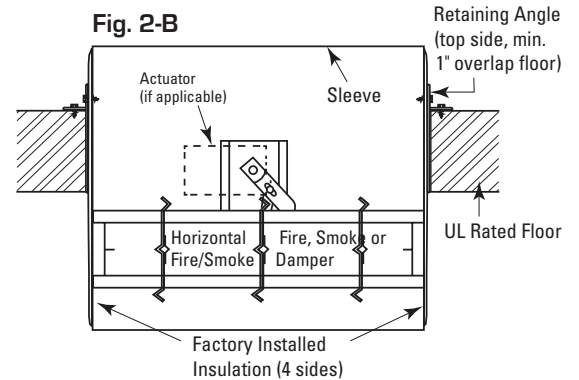

TYPE B & C OUT-OF-WALL/FLOOR APPLICATIONS

Guidelines:

- A. Masonry/concrete walls or floors and stud/gypsum walls.
- B. 1 ½ Hour rated Type B (Fig. 3) or Type C (Fig. 4) fire dampers.
- C. Vertical or Horizontal (angle or flange on top side only) orientation. The maximum size shall be 36" (914 mm) wide by 48" (1219mm) high up to the maximum multi-section UL approved damper size (see Underwriter's Laboratories Listings for maximum assembly sizes) and refer to CVS's maximum size chart in the document for individual model max sizes.

Installation Notes:

- A. The below diagrams are for reference purposes.
- B. Follow all installation requirements within this IOM as it pertains to:
 1. Flange Length
 2. Angle Placement
 3. Approved Fasteners
 4. Max distance of the fire damper from the fire rated wall or floor

Figure 3: Type B Vertical (Wall)

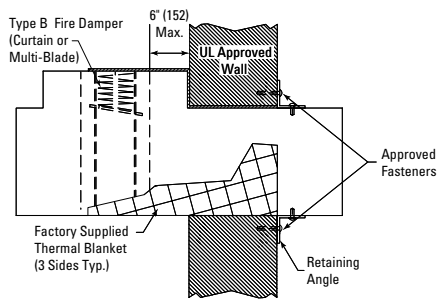

Continuous Duct - 1 Angle Method

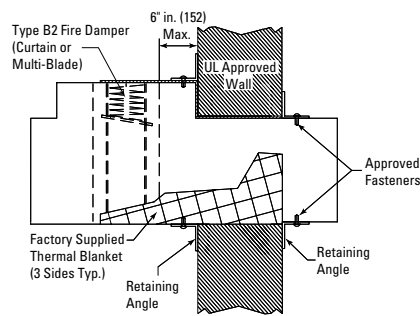

Continuous Duct - 2 Angle Method

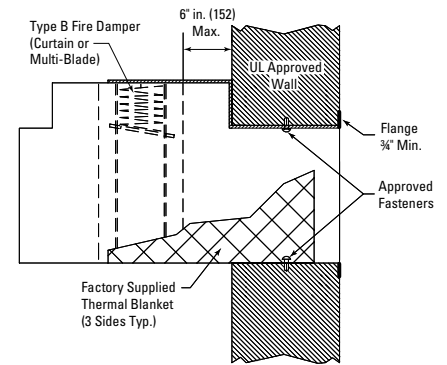

Grille Mount - No Angle Method

Figure 3: Type B Horizontal (Floor)

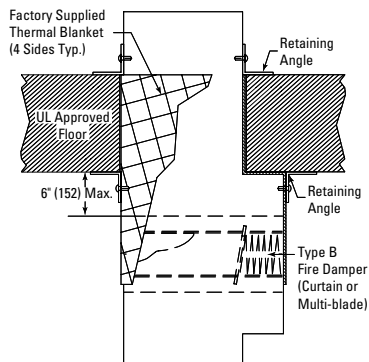

Continuous Duct - 2 Angle Method

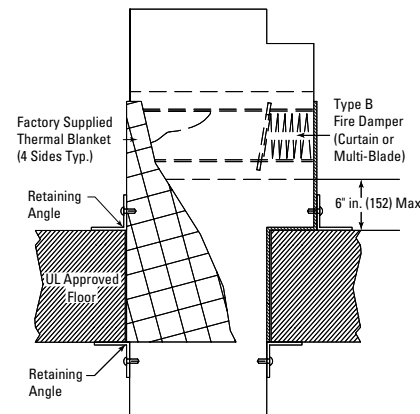

Continuous Duct - 2 Angle Method

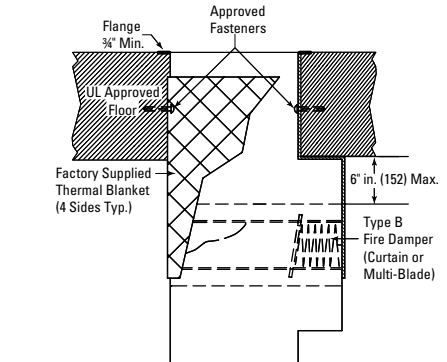

Grille Mount - No Angle Method

Figure 4: Type C (Vertical or Horizontal)

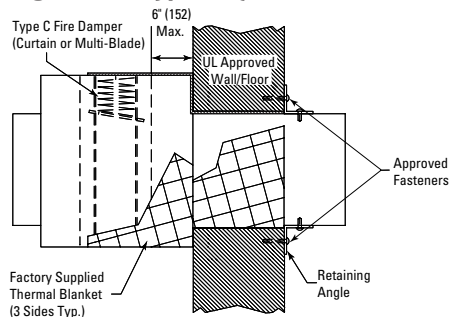

Continuous Duct - 1 Angle Method

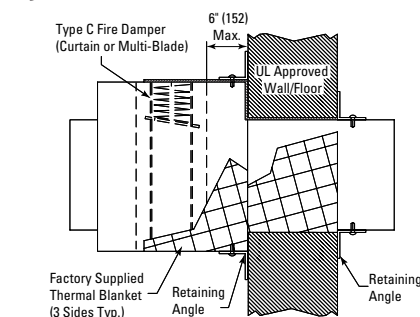

Continuous Duct - 2 Angle Method

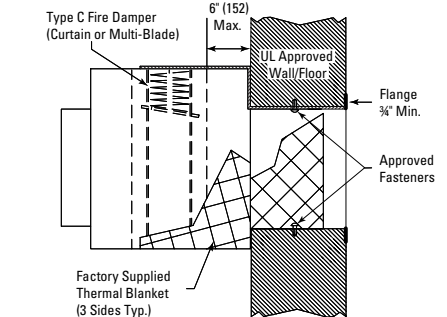

Grille Mount - No Angle Method

Actuator Connections

Electrical or pneumatic connections to damper actuators should be made in accordance with wiring and piping diagrams developed in compliance with applicable codes, ordinances and regulations. Be sure to check actuator for proper voltage and current draw. Tampering with the actuator's installation or connecting the actuator to an improper voltage and current may void the warranty.

DAMPER OPERATION, TESTING & MAINTENANCE

The procedures discussed here are intended to insure that nothing interferes with a damper's proper operation and to identify and eliminate a number of potential situations that could occur and interfere with said operation.

Fire, Smoke & Fire/Smoke Damper Operation:

All CVS fire, smoke and fire/smoke dampers are operated at the factory, however pre-installation testing of its operation can be completed. To test fire dampers, bend the straps that hold the fusible link and temporarily removing the fusible link. Place the damper in its intended installation orientation (vertical or horizontal) and allow the curtain-style blade to close. To test Combination Fire/Smoke Dampers, power the actuator open and remove the power for it to close.

WARNING: During any operating, inspection or testing of fusible link or actuator operated dampers, CVS recommends the following:

1. Caution is advised when a fusible link is released or power is removed from an actuator. Gravity, spring or actuator operated dampers may slam closed causing an abrupt interruption of airflow. As this could cause damage to ductwork, consideration should be given to conducting these tests without system airflow.
2. When removing the fusible link to check damper operation, be sure to keep fingers, hands and any other body parts out of the blade travel path to prevent injury.
3. Check closure springs and actuators (if applicable). If defective, contact damper manufacturer for replacement procedures.

Fire, Smoke & Fire/Smoke Damper Testing:

All fire, smoke and fire/smoke dampers and their fusible links and/or actuators shall be visually inspected and cycled at specific time intervals in accordance with the local building codes or the latest editions of NFPA 90A, 92A, local codes and UL 864. Also refer to the actuator manufacturer's recommendation if applicable.

IMPORTANT NOTE: Do not apply a heat gun, flame or any heat producing device directly to the thermostat. Simply disconnecting the power to the actuator(s) shall be sufficient for testing procedures.

Fire, Smoke & Fire/Smoke Damper Maintenance:

Fire Life-Safety related dampers that are properly applied, equipped with the appropriate UL labels, appropriately installed, and demonstrated to function as intended through a building commissioning process should require no specific preventive maintenance. However, CVS recommends that obstructions, dirt build up, and any rust or corrosion be removed using mild solvents or detergents. No lubrication is required, however if it is desired, damper tracks and blade hinges may be lubricated using a dry lubricant.

Never use a petroleum based lubricant as it will attract dust and eventually impede a damper's operation.

Message from CVS :

This installation, operation and maintenance instruction document has been reviewed and approved by the Underwriter's Laboratories.

As a part of CVS's continuous improvement program, CVS reserves the right to make further improvements or changes without notice.